

Loyal Single-Chain Galvanized Elevator 11" Wide

Model with trough chain-tightener on discharge end.

Owner's and Operator's Manual

WARNING

This elevator has rotating and moving parts.
Use care during operation and maintenance.

(Model L11)

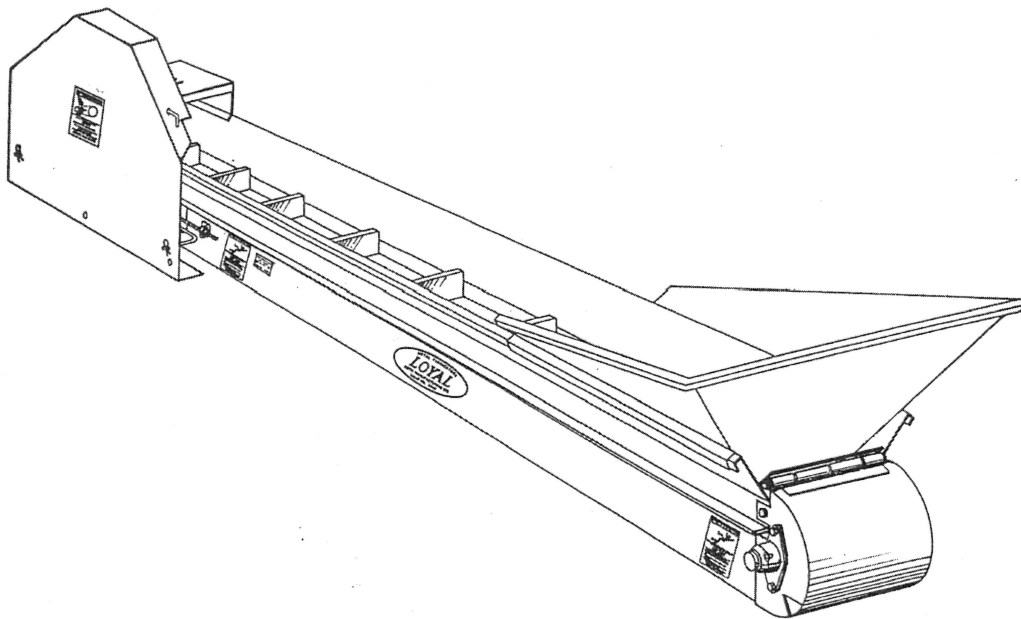

WARNING

Read and understand this operator's manual prior to operating this equipment. Failure to follow these instructions could result in personal injury or damage to the equipment.

Additional Assistance

If any items covered in this manual are not fully understood by you, contact Roth Mfg. Co. Inc., 314 E. Elm Drive, P.O. Box 40, Loyal, WI 54446, E-mail info@loyal-roth.com (call 1-800-472-2341).
www.loyal-roth.com

Machine Identification

The **serial number plate** is located to the right of the motor shield.

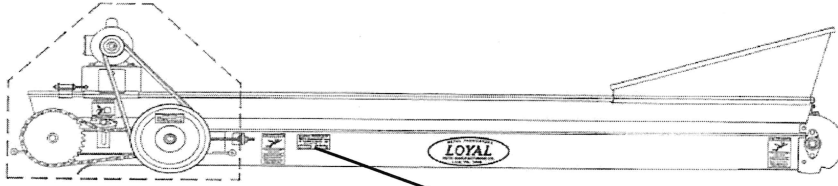

Please record the following information below:

Serial No. _____

Model No. _____

Date of Purchase _____

Purchased From _____

For Additional Assistance Contact:

Roth Mfg. Co. Inc.
P.O. Box 40
314 E. Elm Drive
Loyal, WI 54446
E-mail info@loyal-roth.com
Phone: 1-800-472-2341
www.loyal-roth.com

Table of Contents

Machine Identification.....	2
Introduction.....	4
Safety Information.....	5
Safety Labels.....	6
Safety...Electric Motor Drive.....	7
Assembly Instructions.....	8-9
Operating Instructions.....	10
Elevator Shutdown.....	10
Break-In.....	10
Trouble Shooting Guide.....	11
Maintenance.....	12
Parts List.....	16-19
Warranty Registration Form.....	22
Warranty.....	23

Introduction

Thank you for purchasing a Loyal farm equipment product from Roth Mfg. Co. Inc. We welcome you to our growing family of new product owners. Proper assembly, maintenance, and safe operating practices will help you get satisfactory use from this product.

Intended Use

This product is built by Roth Mfg. Co. Inc. and is intended to convey silage, haylage and other similar materials. It is not designed to be used for any other purpose other than its intended use.

Using this Manual

This manual is designed to help familiarize the operator with the safety, assembly, operation, adjustments, troubleshooting, and maintenance expectations of this machine and create awareness of the hazards that may be encountered because of its use. The intent of this manual is to provide specific machine guidelines and help owners and operators obtain the best results and safe operation from their investment with a focus on accident and injury prevention.

All users must read and understand the information in this manual prior to operation. Do not allow anyone to operate or maintain this equipment who has not fully read and understood this manual. Failure to follow the procedures described in this manual could result in equipment damage or physical injury or death to you or bystanders.

Keep this manual with the machine for future reference as it is considered part of your machine. The life of any machine depends largely on the care it is given. You should refer to and review the manual often for preventative maintenance.

If you require information not covered in this manual, contact:

Roth Mfg. Co. Inc., 314 E. Elm Drive, P.O. Box 40, Loyal, WI 54446
E-mail info@loyal-roth.com (call toll-free 1-800-472-2341) for assistance.
www.loyal-roth.com

Because Loyal engineers are constantly improving products, Roth Mfg. Co. Inc. reserves the right to change design and/or specifications without notice. The information on this document does not constitute a warranty by Roth Mfg. Co. Inc.

Safety Information

When operating this equipment, you are responsible for your own safety and the safety of those around you. This machine is designed and equipped with proper safety features, including machine guards and safety labels, to protect you and bystanders from hazards that could cause serious injury. Guards and safety labels serve a critical purpose and must not be altered. Guards should only be removed for maintenance purposes and must be reinstalled prior to operation. Some of the illustrations in this manual may show the equipment with machine guards removed for clarity. Never operate this machine unless all machine guards are in place.

Safety Alert Symbol



This is the safety alert symbol. It is used to alert you to potential physical injury hazards. Obey all safety messages that follow this symbol to avoid possible injury or death.

Safety Signal Words

The safety labels on the machine and safety messages in this manual use a combination of symbols, signal words, and color-coding to identify the following hazardous situations or safety practices:



DANGER indicates a hazardous situation which, if not avoided, will result in death or serious injury.



WARNING indicates a hazardous situation which, if not avoided, could result in death or serious injury.



CAUTION indicates a hazardous situation which, if not avoided, could result in minor or moderate injury.

NOTICE

NOTICE is used to address practices not related to physical injury.

SAFETY INSTRUCTIONS

SAFETY INSTRUCTIONS (or equivalent) is used to indicate specific safety-related instructions or procedures.

Additional Definitions

Note indicates a special point of information that the operator should be aware of before continuing.

Important indicates a point of information related to the following topic. This information must be read and understood before continuing.

Safety Labels

The Safety Labels Shown On This Page Must Be Displayed As Shown Below

Safety labels must be replaced if they are destroyed, missing, painted over, or can no longer be read. New equipment components installed during repair shall be equipped with the same safety labels that were affixed to the original components. Keep labels always wiped clean. For free replacements contact: Roth Mfg. Co. Inc., P.O. Box 40, Loyal, WI 54446 (1-800-472-2341)

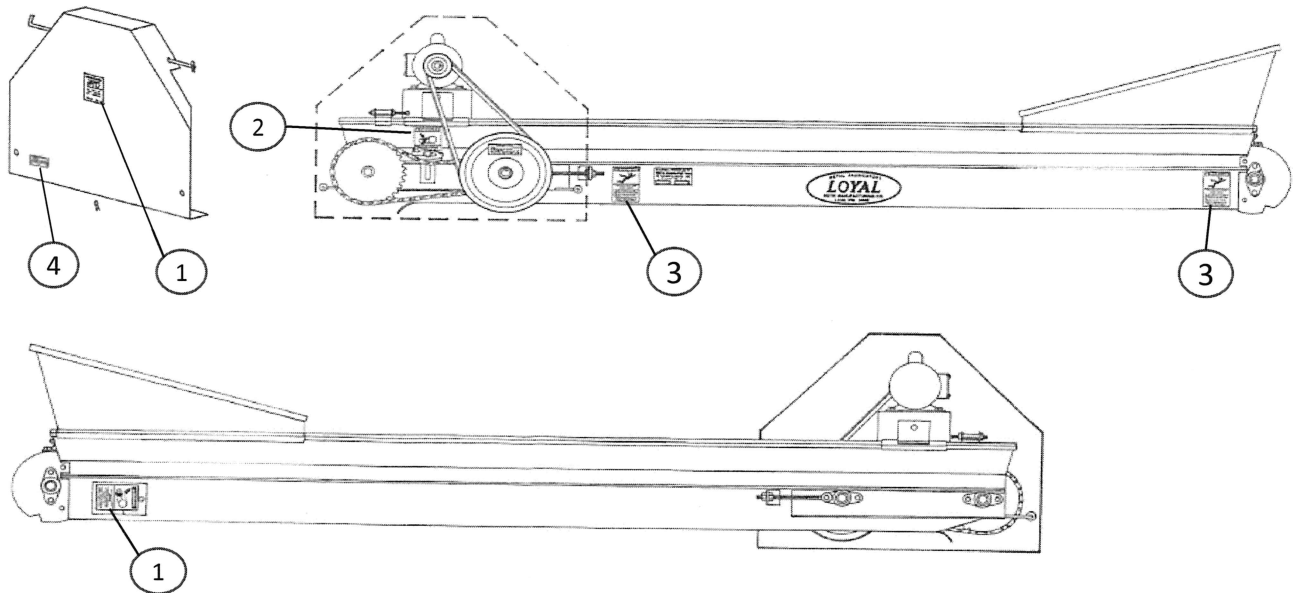

1



Part No. 11096

2



Part No. 11097

3



Part No. 11098

4

California Proposition 65
WARNING
 This product can expose you to chemicals including nickel, which is known to the State of California to cause cancer, and hexavalent chromium, which is known to the State of California to cause birth defects or other reproductive harm.
 For more information: www.P65Warnings.ca.gov

Part No. 14208

Safety - Electric Motor Drive

1. Electric motors and controls shall be installed by a certified electrician and must meet the standards set by the National Electrical Code and all local and state codes.
2. Install a main power disconnect switch in the line from the panel to the elevator. The main power disconnect switch must be located near the elevator, for ease of use and safety. When turned OFF, the main power disconnect switch shuts off all power to the elevator.
3. You must disconnect and lockout power source before resetting your motor or working on the equipment.
4. Reset and motor starting controls must be located so that the operator has full view of the entire operation.
5. A magnetic starter should be used to protect your motor.
6. Electric motor must be totally enclosed, fan cooled and have a manual reset overload protector. Use a motor that is rated between 1725 to 1800 RPM.
7. Use a 2.8" O.D. Type A, cast iron motor pulley (not included).
8. Be sure that the wiring to the electric motor is large enough and the power source is the right voltage and frequency for the motor used.
9. Make certain that all electrical assemblies are grounded and located in a weatherproof dry location. Never use an electric motor in an area where there is standing water or if it is extremely wet. Electrical leakage can cause shock or electrocution in wet conditions.
10. Do not operate equipment without all shielding in place.
11. Keep electric motors and motor fans clean of hay and dust. This will allow motor to cool properly.
12. Be certain to keep all wiring and controls out of reach of livestock and children.
13. Check and determine that the belts are in line.
14. Make certain that the belts are snugged up but not overtightened. Overtightened belts will cause pulley and bearing failure. If belt tension is correct, belt can be depressed about 1/2" to 3/4" at midpoint between pulleys. Replace pulleys when the pulley grooves are worn enough to cause belt slippage.
15. Make certain that the motor horsepower is adequate and is properly matched to the motor pulley.
16. Do not use an electric motor of lower horsepower than specified in our "Selecting the Right Size Motor" guide. Failure to heed these instructions can result in personal injury or death.

17. Selecting the Right Size Motor

Elevator Length	9" Width	11" Width	13" Width
6' to 10'	3/4 HP	3/4 HP	3/4 to 1 HP
10' to 24'	1 HP	1 HP	1 to 1-1/2 HP
24' to 36'	1 to 1-1/2 HP	1-1/2 HP	1-1/2 HP - 2 HP
36' to 50'	1-1/2 HP*	1-1/2 HP	1-1/2 HP - 2 HP
50' to 60'		2 HP	

18. Recommended Maximum Length

Elevator Width	Maximum Length
9"	42'
11"	60'
13"	48'

*Refer to "Recommended Maximum Length" table.

Assembly Instructions

1. Lay out some 4" x 4" x 2' long wood blocking onto ground. Place elevator or elevator sections onto the wood blocks. The wood blocking will keep the elevator off ground, prevent tongue and pulley from bending, and aid assembly.
2. Connect the lower pintle chain.
3. Slide elevator sections together. Overlap top steel pan like a shingle so pintle chain flight travels off first pan and drops onto next pan without snagging.
4. Overlap poly liner like a shingle so pintle chain flight travels off first section of poly and drops onto next section without snagging.
5. Poly is attached to elevator or elevator sections at one end only.
6. Poly cannot be attached at both ends of elevator or sections as it expands as temperatures increase and contracts as temperature decreases.
7. Connect angle iron joints together.
8. Connect the upper pintle chain.
9. Tighten the pintle chain. At drive end of elevator (loosen or tighten nuts on eye-bolts to move sliding bearing mounts ahead or back).
10. Chain is properly tightened if on 16 ft unit it can be easily raised about 4" at the center with your hand; on 20 ft. unit, 5" etc.
11. If chain is too tight it will cause premature wear of the bearings. If chain is too loose it may snag when entering the bottom trough.
12. Install 12" pulley.
13. Install motor and V-belt. Make certain the belt is snugged up but not overtightened. Overtightened belts will cause pulley and bearing failure. If belt tension is correct, belt can be depressed about 1/2" to 3/4" at midpoint between pulleys. Refer to "Safety...Electric Motor Drive" page of this manual before installing motor.

Selecting the Right Size Motor			
Elevator Length	9" Width	11" Width	13" Width
6' to 10'	3/4 HP	3/4 HP	3/4 to 1 HP
10' to 24'	1 HP	1 HP	1 to 1-1/2 HP
24' to 36'	1 to 1-1/2 HP	1-1/2 HP	1-1/2 HP - 2 HP
36' to 50'	1-1/2 HP*	1-1/2 HP	1-1/2 HP - 2 HP
50' to 60'		2 HP	

Recommended Maximum Length	
Elevator Width	Maximum Length
9"	42'
11"	60'
13"	48'

*Refer to "Recommended Maximum Length" table.

Assembly

14. Install drive shield.

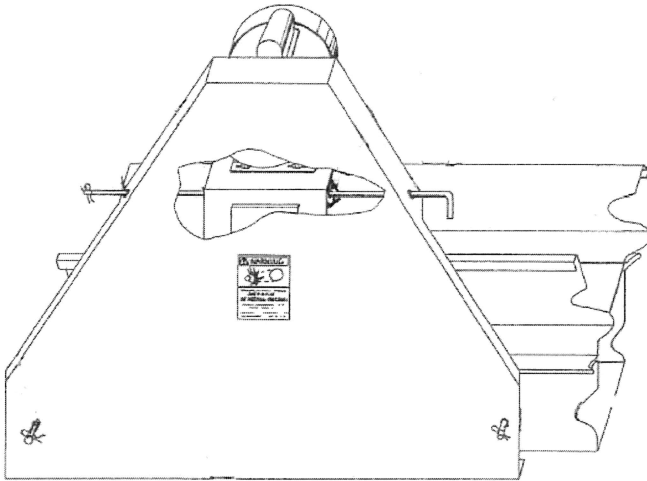

15. Install Hopper.

- Slide hopper onto elevator top flange.
- Bend tips of trough flanges at boot end of elevator (Location A below), to prevent hopper from sliding off elevator.
- Using pliers, tightly crimp two ends on each side of hopper (location B below) to wrap them around elevator top flange.

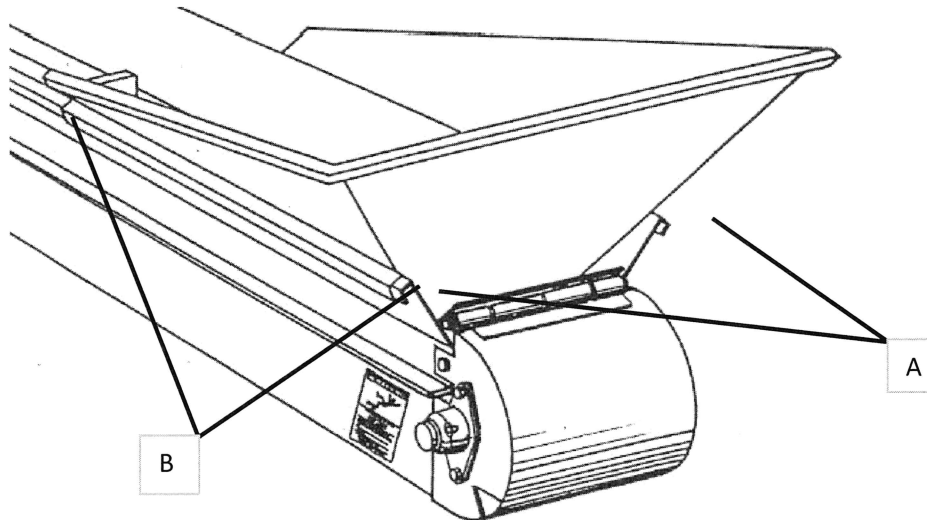

16. Install covers on lower section of elevator within 7 ft of floor or working level, or within reach of people at floor level (see parts list section of this manual to order).

Operating Instructions

1. Never start the machine until all safety shields are in place, secured and functional.
2. If shields or safety labels become damaged or lost, contact dealer or factory for FREE replacements (see "Parts List" section of this manual to order).
3. Use covers (available from factory), on lower sections of elevator within 7 ft of floor or working level, or within reach of people (see "Parts List" section of this manual to order).
4. Check that belts and chains are properly adjusted (see "Maintenance" section of this manual).
5. Check all lubrication points (see "Maintenance" section of this manual).
6. Make certain everyone is clear before starting, operating or moving the machine.
7. Loose or floppy clothing should not be worn by the operator.
8. Keep hands, feet, hair, clothing, jewelry and other foreign objects well away from all moving parts when machine is in operation.
9. Do not step on or over elevator when it is in motion. Never climb on, or crawl or ride up elevator. Never stand under a suspended elevator.
10. Always start elevator and make sure full power is available before loading hopper.
11. The greatest capacity is obtained when the hopper is just full enough to keep flights carrying all they can at the angle of operation. Trying to force the operation beyond this point will result in less material being handled.
12. Do not clean, unplug, adjust or service the machine when any part is in motion.
13. Disconnect and lock out power source before adjusting or servicing elevator or before resetting motor overload (see "Electric Motor Drive" section of this manual).
14. Always close cleanout door after cleaning out boot. Be sure it is securely fastened.

Elevator Shutdown

Normal Shutdown:

1. Always allow hopper and flights to empty before stopping the elevator. This will avoid clogging, freezing problems and help prevent rusting from feed acids.
2. Disconnect power source before operator leaves work area.

Emergency Shutdown:

1. Disconnect and lockout the power source if elevator shuts down under load. Clear as much material from elevator possible. Never attempt to restart when full.
2. Starting the unit under load may result in damage to the elevator. Such damage is considered abuse of the equipment.

Break-In Instructions

New elevators or elevators that have set idle should be broken in properly. Check and make sure that all bearings contain grease. Pour a light stream of oil onto elevator chain before running elevator. Oil will reduce friction, quiet elevator and greatly extend chain life. Lubricate the drive roller chain with SAE90 gear lube. It clings and gives excellent lubrication. Lubricate the chain tightener eye bolt threads.

Check and tighten any loose fasteners, belts and chains. Elevator chains should be adjusted in the following order.

1. You must disconnect and lockout power source before working on the equipment.
2. Loosen chain tensioner and remove extra links from conveyor chain.
3. Connect and retighten conveyor chain until snug.

Important: first remove extra chain links before using chain tightener. Failure to remove extra chain links will result in chain tightener not being able to take up all the loose chain.

Trouble Shooting Guide

1. **Problem:** Elevator Clogs.

Possible Cause: Material possibly being fed into hopper too fast.

Solution: Feed materials into hopper at slower rate.

Possible Cause: Discharge end is too close to pile it is discharging into and material is being dragged back from discharge end by the returning chain flights.

Solution: Raise discharge end to allow more clearance from pile.

Possible Cause: Elevator may be positioned at too steep of an angle.

Solution: Decrease elevator angle if possible.

Possible Cause: Materials may be overflowing into the red boot from the hopper.

Solution: Move hopper up the elevator so the material will fall onto the pan and not into the boot.

Possible Cause: Boot agitator is missing, and material is flowing back down into boot.

Solution: Install boot agitator (see "Parts List" section of this Manual to order).

2. **Problem:** Chain is snagging at idler end elevator.

Possible Cause: Idler end trough is worn out. Chain travels around idler sprocket and fails to ramp up onto pan and poly liner.

Solution: Replace elevator idler end.

Possible Cause: Elevator boot is worn out.

Solution: Replace elevator boot(see "Parts List" section of this Manual to order).

3. **Problem:** Chain is snagging near drive end of elevator.

Possible Cause: Elevator tongue is missing or worn out. Tongue is located on drive end of elevator. Chain travels around drive sprocket, onto Tongue which guides chain into return trough.

Solution: Install new tongue (see "Parts List" section of this Manual to order).

4. **Problem:** Chain is snagging on elevator trough.

Possible Cause: Trough is worn out and has holes that chain is catching on.

Solution: Replace elevator.

5. **Problem:** Elevator will not start.

Possible Cause: Chain may be frozen down onto elevator.

Solution: Break chain loose before starting elevator.

Possible Cause: Boot end may be full of frozen water or material.

Solution: Remove all material from inside boot

6. **Problem:** Chain rides on top of material.

Possible Cause: Material being fed to fast into hopper.

Solution: Feed material into hopper at slower rate.

Possible Cause: Elevator chain may be loose.

Solution: Tighten chain (see "Service and Maintenance" section of this Manual).

7. **Problem:** Chain flights are bending or breaking off from chain.

Possible Cause: Boot may be full of frozen water or silage and flight is unable to pass freely inside of boot.

Solution: Clear frozen material or obstruction from boot.

Maintenance

Never service elevator while running or with power source connected. Disconnect and lock out power source before unplugging, adjusting, or servicing to prevent unexpected application of power.

Always replace all safety shields and covers before restarting elevator. If shields become damaged or lost, contact factory for Free replacements (See “Parts list” section of this Manual to order).

Safety Label Maintenance

Make sure all safety labels are in place and are readable. Clean safety labels with a warm, moist cloth. Safety labels must be replaced if they are destroyed, missing, painted over, or can no longer be read. For free replacements, contact factory (see “Parts list” section of this manual to order).

Lubrication Instructions

As with any type of equipment, the life of the unit is dependent upon the lubrication care given by the operator. Lubrication should be done at regular intervals to avoid premature failure. Service of the complete unit should take place if the machine has been allowed to set for a period of time.

Bearing Lubrication:

All bronze pillow block bearings on the driveshaft, cross shaft and idler shaft have grease zerks. They should be greased every 15 hours and checked for looseness or seizing to shaft. Extend life by scheduled greasing.

Chain Lubrication:

Pour a light stream of heavy oil onto the elevator chain. Oil will reduce friction, quiet elevator and greatly extend chain life. Lubricate the drive roller chain with SAE 90 gear lube. It clings and gives excellent lubrication.

Preventative Maintenance Check List

Although this type of equipment has few lubrication points (see “Lubrication Instructions” section of this Manual), there are certain areas that should be inspected daily which will aid the operator in preventing needless breakdowns in the machine. Following is a “Check List” of these areas.

1. Inspect all bearings. Faulty bearings can cause damage to the entire unit. Replace if noisy, loose or damaged.
2. Inspect conveyor chain:
 - a) Replace worn or broken links.
 - b) Adjust chain tension if it's too loose or too tight.
3. Inspect roller chain and belt for proper tension, alignment and wear. Replace or adjust if necessary.
4. Check all hardware and make sure all are tightened securely.
5. Keep electric motors and motor fans clean of material and dust. This will allow motor to cool properly.

Notes

Notes

End

11" Wide Single-Chain Elevator Parts List

Model with trough-chain tightener located on discharge end of elevator.

Drive End (with pintle chain)

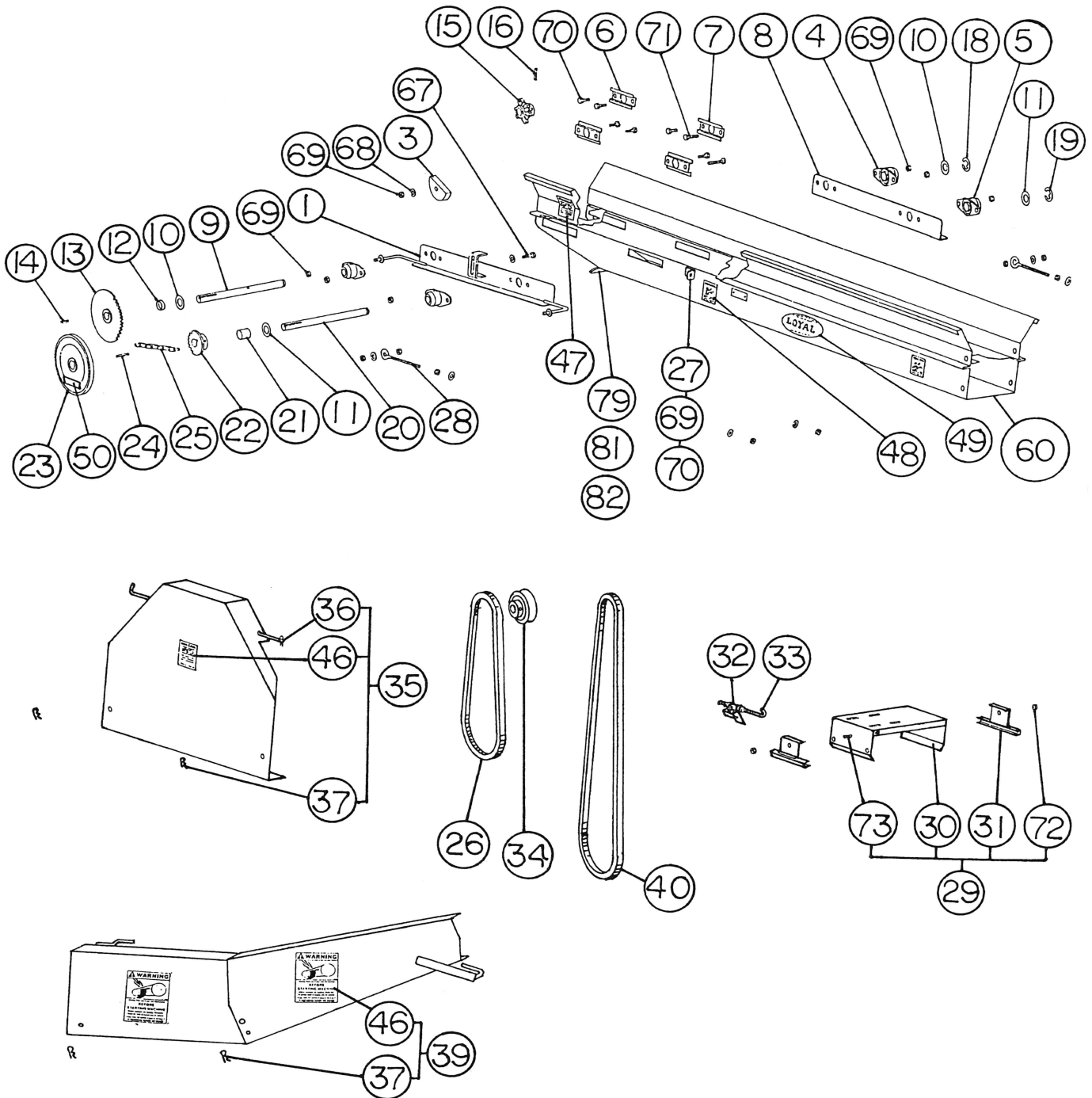

11" Wide Single-Chain Elevator Parts List

Model with trough-chain tightener located on discharge end of elevator.

Drive End (with pintle chain)

Ref. No.	Part No.	Description	No. Req'd
1	E7115	MOUNT,7-13"ELV CHAIN TIGHT(LT)	1
3	E772	BLOCK,ROLLER CH TIGHTENER WOOD	1
4	E1179	BEARING W/ZERK,BRONZE,1-1/4"ID	2
5	E979	BEARING W/ZERK,BRONZE,1" ID	2
6	E1147	SLIDE,11/13" ELV BEARING MOUNT	2
7	E1147	SLIDE,11/13" ELV BEARING MOUNT	2
8	E7116	MOUNT,7-16"ELV CHAIN TIGHT(RT)	1
9	E1144P	SHAFT,DRIVE,1-1/4" X 16-3/4"L	1
10	F806080	BUSH,MACH,14X1-9/32X1-7/8",UPL	2
11	F806060	BUSH,MACH,18X1-1/32X1-1/2",UPL	2
12	E11105	PIPE,PVC,S/40 X 1.25" X .25"	1
13	E1169	SPROCKET,DR SHFT,4060 X 1-1/4"	1
14	F203060	KEY,SQUARE,1/4X1/4X1",UPLT	1
15	E1143	SPROCKET,#667HX6-TOOTH X 1-1/4"	1
16	F407080	PIN,ROLL,5/16X2-1/2",PLT	1
18	F503070	RING,E-RET,.05X1.08X1.6",UPLT	1
19	F503040	RING,E-RET,.05X.625X1.5",UPLT	1
20	E1111	SHAFT,CROSS,1" X 17-3/4"L	1
21	E9106	PIPE,PVC,S/40 X 1" X 5/8"	1
22	E989	SPROCKET,X-SHAFT,4018 X 1"ID	1
23	E986	PULLEY W/DECAL,X-SHAFT,12X1"ID	1
24	F203071	KEY,SQUARE,1/4X1/4X2-1/4",UPLT	1
25	E771	CHAIN W/CL ENDLESS,ROL,40X106P	1
26	AX54	V-BELT,AX54,NOTCHED	1
27	E7117	MOUNT,7 TO 13" ELEV I-BOLT	2
28	E745	I-BOLT W/FASTENERS,3/8 X 7"L	2
29	E1165	MOTOR MOUNT L/TIGHTNER KIT,11"	1
30	E1177	MOUNT ONLY,MOTOR,8.5" X 16.25"	1
31	E766	CLAMP,7-13"ELV MOTOR SLIDE,8"L	2
32	E767	CLAMP,GALV ELEV BELT TIGHTNER	1
33	E755	J-BOLT W/FASTENERS,5/16 X5-3/4	1
34	AK28X5/8	PULLEY,CAST IRON,AK28 X 5/8"ID	1
35	E761	SHIELD,7TO13" ELEV DRIVE(1-PC)	1
36	E705	X-ROD W/HAIR PINS(1-PC DR SHD)	1
37	F405050	PIN,HAIR,#17X0.08"X1.625",PLT	3
38	Y145	MANUAL,11"ELEV. W/PINTLE CHAIN	1
		FOR ELEVATORS WITH 2-DRIVE SHIELDS OR TRANSPORT	
39	E763	SHIELD,DRIVE(2-PC),7to13" ELEV	1
40	AX98	V-BELT,AX98,NOTCHED	1
		MISCELLANEOUS	
46	11096	DECAL,WARNING-BEFORE STARTING	1
47	11097	DECAL,DANGER-SHIELDS ARE OFF	1
48	11098	DECAL,WARNING-STAY AWAY	2
49	11099	DECAL,LOYAL,LARGE OVAL,YEL&BL	1
50	11100	DECAL,IMPORTANT	1
60		CONTACT FACTORY	-
67	F1072357	HHCS,5/16-18X1-3/4",G5,PLT	1
68	F808030	WA,STD FLT,5/16",PLT	6
69	F354040	NUT,HEX,5/16-18,G5,PLT	17
70	F1072320	HHCS,5/16-18X5/8",G5,PLT	10
71	F108620	HH TAP BOLT,5/16-18X1.25",G5,P	2
72	F354050	NUT,HEX,3/8-16,G5,PLT	4
73	F1072455	HHCS,3/8-16X1-1/4",G5,PLT	4
79	E11118	TONGUE,TROUGH,3" X 10-3/4"	1
81	F356030	NUT,NY-IN LOCK,1/4-20,G2,PLT	3
82	F302030	MS,FL-HD,SL,1/4-20X3/4",G2,PLT	3



WARNING Do not substitute Grade 2 bolts when stronger Grade 5 bolts are specified.

Failure to heed these instructions could result in serious personal injury or death!

11" Wide Single-Chain Elevator Parts List

Model with trough-chain tightener located on discharge end of elevator.

Idler End (with pintle chain)

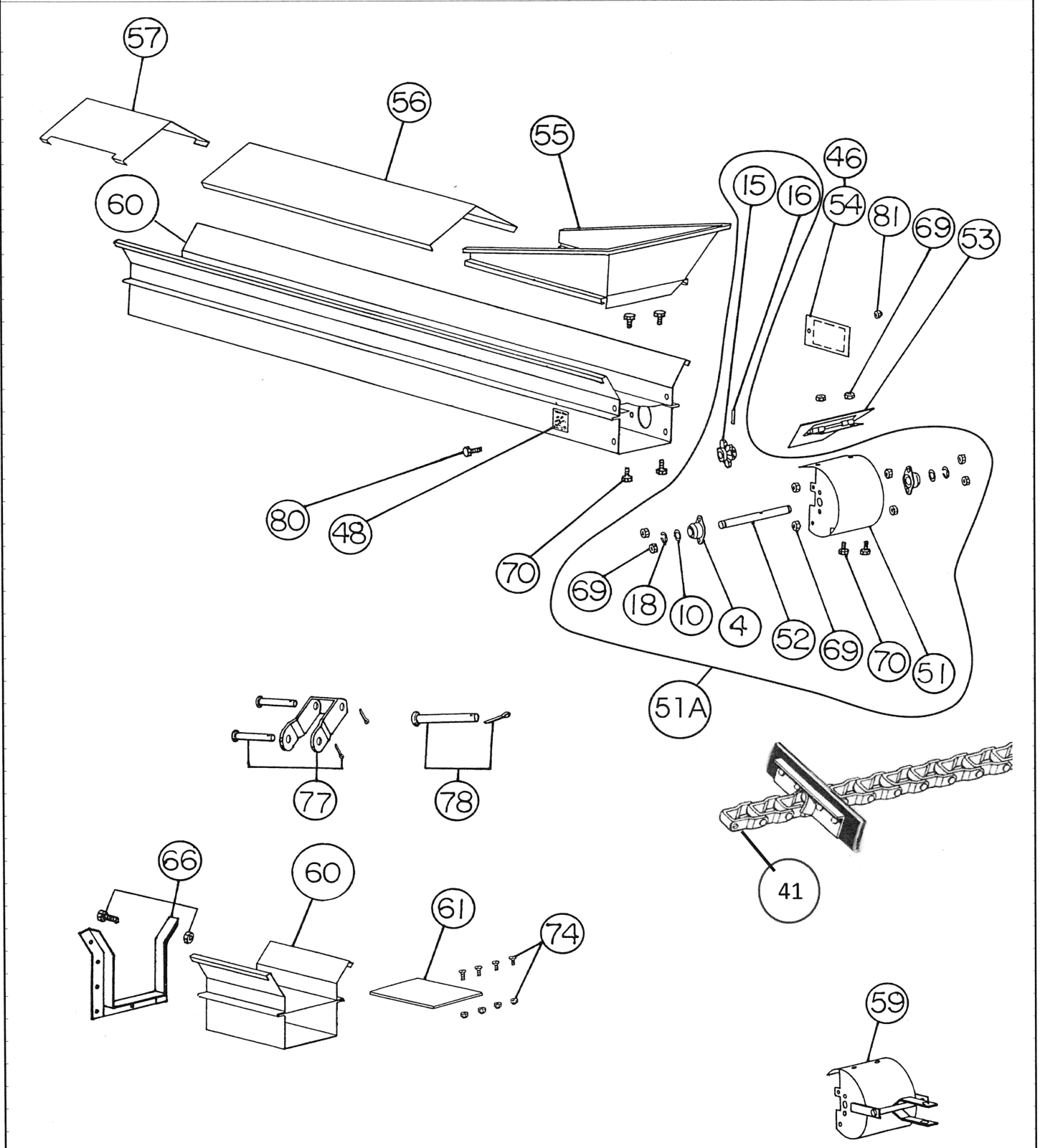

Idler End (with pintle chain)			
Ref. No.	Part No.	Description	No. Req'd
4	E1179	BEARING W/ZERK,BRONZE,1-1/4"ID	2
10	F806080	BUSH,MACH,14X1-9/32X1-7/8",UPL	2
15	E1143	SPROCKET,#667HX6-TOOTH X 1-1/4	1
16	F407080	PIN,ROLL,5/16X2-1/2",PLT	1
18	F503070	RING,E-RET,.05X1.08X1.6",UPLT	2
41	PC667H10	CHAIN,PINT,#667H,10" FLIGHT	-
46	11096	DECAL,WARNING-BEFORE STARTING	1
48	11098	DECAL,WARNING-STAY AWAY	1
51	E1148	BOOT ONLY,11"ELV,PINTLE/DETACH	1
51A	E1148-K	BOOT L/AGIT KIT,11" G ELEV,DET (includes 1 of E1143, 1 of E1142P, qty 2 of E1179, 1 of E1148, 8 of F1072320, 1 of F407080, 2 of F503070, 2 of F806080, 8 of F354040).	-
52	E1142P	SHAFT,IDLER,1-1/4 X 14-7/8"L	1
53	E1112	AGITATOR W/HINGE,11" ELEV BOOT	1
54	E7114	DOOR WITH DECAL,CLEANOUT	1
55	E1149	HOPPER,11"GALV ELEV INCLINE	1
56	EC118	COVER,GALV ELEV,11" X 8'L	-
56	EC114	COVER,GALV ELEV,11" X 4'L	-
57	EC112M	COVER,MOTOR MT TROUGH,11"X 2'L	-
59	E1178	BOOT ONLY W/HITCH,11" ELEV	1
59A	E1178P-K	BOOT L/AGIT KIT,11" G EL,PINTL (includes 1 of E1143, 1 of E1142P, qty 2 of E1179, 1 of E1178, 8 of F1072320, 1 of F407080, 2 of F503070, 2 of F806080, 8 of F354040).	-
60		CONTACT FACTORY	-
61	PL141078	LINER,POLY,1/4"X10-7/8" WIDE	-
66	J11	JOINT W/GR 5 HDWE,11" CONNECT	1
69	F354040	NUT,HEX,5/16-18,G5,PLT	10
70	F1072320	HHCS,5/16-18X5/8",G5,PLT	10
74	E709	FASTENER KIT,POLY-LINER TO PAN	1
77	E667C	COUPLER W/PIN&CLIP,#667H PINTL	-
78	E667HPC	PIN&CLIP,REPAIR,#667H PINTLE	-
80	F1072245	HHCS,1/4-20X3/4",G5,PLT	1
81	F356030	NUT,NY-IN LOCK,1/4-20,G2,PLT	1
 WARNING Do not substitute Grade 2 bolts when stronger Grade 5 bolts are specified. Failure to heed these instructions could result in serious personal injury or death!			

Roth Mfg. Co. Inc.
P.O. Box 40
314 E. Elm Drive
Loyal, WI 54446
E-mail: info@loyal-roth.com
Phone: 1-800-472-2341
www.loyal-roth.com

Warranty Registration Form

Fill out all lines on this form to make the warranty effective. Form must be completely filled out to activate warranty. Mail within 30 days of purchase to: Roth Mfg. Co. Inc., P.O. Box 40, Loyal, WI 54446

Name:

Address:

City:

State:

Zip Code:

Purchase Date:

Purchased From:

City:

State:

Zip Code:

(See Illustration below for Serial No. and Model No. location).

Machine Serial No.

Machine Model No.

I have read and understand the Owner's and Operators Manual. The product has been assembled and the 'Shields' and 'Decals' have been installed as shown in this manual.

Signature:

Date:

The serial number plate is located to the right of the motor shield.

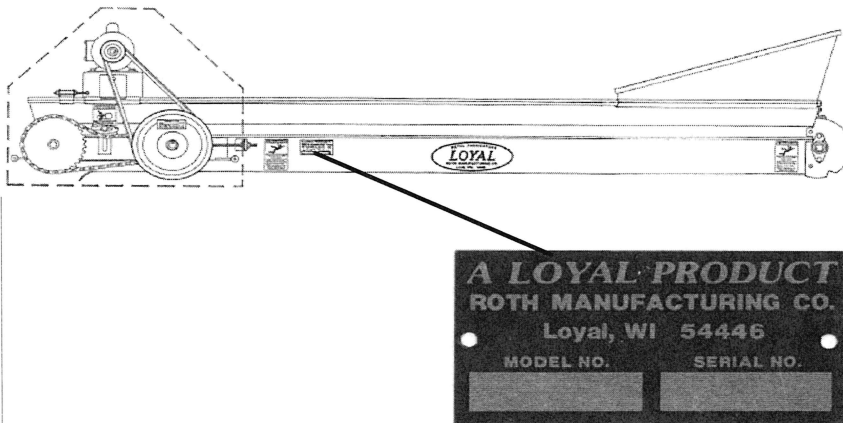

Limited Warranty

Roth Mfg. Co. Inc. warrants to the original purchaser, that this unit will be free from defects in material and/or workmanship under normal farm use and service, for a period of one-year from date of original sale. Should such defect occur within warranty period, the liability of Roth Mfg. Co. Inc., its employees, agents, authorized distributors, and dealers (hereinafter collectively referred to as sellers) is hereby expressly limited to repairing or, at its option, replacing free of charge at its factory, any part or parts found upon examination by factory to be defective in material or workmanship or both; this is the exclusive remedy. The purchaser is responsible for transportation cost of the equipment for warranty service or for any service call expense. Sellers liability is further expressly limited with respect to components manufactured by others, such as, but not limited to tubes, tires, bearings, pintle or detachable link and roller chains, or other trade accessories; to the extent of such warranties as are extended to sellers by these manufacturers. This warranty shall apply only within the boundaries of the continental United States.

This warranty does not cover normal wear items such as pintle or detachable chains, sprockets, bearings, etc.

Notice of defect shall be furnished in writing to the Seller and to the agent through whom the unit was purchased, disclosing in full all known defects and failure in operation and use. Reasonable time shall be given to the Seller to remedy any such defects and failures.

This warranty is in lieu of all other warranties, expressed (except as set forth within) or implied, including but not limited to warranties of merchantability and fitness for a particular purpose. Manufacturer makes no warranty as to the design, capability, capacity, nor suitability for use of the unit. The obligation and liability of sellers under this warranty does not extend to loss of crops, loss because of delay in harvesting or any expense or loss incurred for labor, supplies, substitute machinery or rental machinery, transportation, or other charges.

Except as provided herein, manufacturer shall have no liability or responsibility to purchaser or any other person or entity with respect to any liability, loss, or damage caused or alleged to be caused directly or indirectly by the unit including, but not limited to, any indirect, special, consequential, or incidental damages resulting from the use or operation of the unit or any breach of this warranty. Notwithstanding the above limitations and warranties, manufacturer's liability hereunder for damages incurred by purchaser or others shall not exceed the price of the unit.

Roth Mfg. Co. Inc. reserves the right to make changes in design and components or material or to utilize available materials which it deems satisfactory, in order to improve its products. Also, Roth Mfg. Co. Inc., reserves the right to make changes in the construction or design of any parts without incurring any obligations to install these improvements or changes on previously delivered units.

This warranty shall be void if any part or parts not manufactured or supplied by Roth Mfg. Co. Inc., are used either in servicing or maintaining the unit, and sellers obligation to repair or replace parts are then voided. This warranty shall be void if in the judgement of Roth Mfg. Co. Inc., repairs are made in such a manner to affect this unit in a materially adverse manner or if this unit is operated unsafe or while in a state of disrepair. This warranty shall be void if equipment is used for commercial, industrial, lease, rental, custom operation and non-agricultural use. Any damage to this product as a result of misuse, abuse, neglect, accident, improper installation, alteration, repairs (not out own), improper adjustment, accident, damage by fire, act of God, lack of performing required maintenance or any other use contrary to our instructions will void the warranty. This warranty will be void if the product serial numbers are altered, defaced or removed.

If any provision of this limited warranty shall violate any applicable law and is held to be unenforceable, then the invalidity of such provision shall not invalidate any other provisions herein. Applicable law may provide rights and benefits to purchaser in addition to those provided herein.

The terms and conditions of this warranty cannot be altered, modified, or waived by any seller without the expressed, written consent of an officer of Roth Mfg. Co. Inc.

Notice

Roth Mfg. Co. Inc., disclaims any liability for the operation of the equipment with the safety shields removed or modified. The nature of this product requires that it be operated in a safe way only, and in good repair by qualified persons. Each purchaser, through the process of purchasing this equipment, agrees with T.R. Metal Crafters, Inc., to operate it in a safe manner and in accordance with applicable state and federal laws and agrees to indemnify and hold harmless sellers, from any loss to any person or persons caused by purchaser's failure to do so. Each purchaser further agrees to bring to the attention this notice to each subsequent purchaser, and to obtain his agreement thereto as a condition of resale or transfer.

Important

To make this warranty effective, the Owners "Warranty Registration" card (located inside Owners/Operator's Manual) must be filled out and sent to Roth Mfg. Co. Inc. within 30-days of purchase.

Roth Mfg. Co. Inc.

P.O. Box 40

314 E. Elm Drive

Loyal, WI 54446

E-mail: info@loyal-roth.com

Phone: 1-800-472-2341

www.loyal-roth.com